

MU3 Disc Brake Caliper - Pneumatically applied Spring released

Nominal dimensions given
For caliper dimensions see DS1000

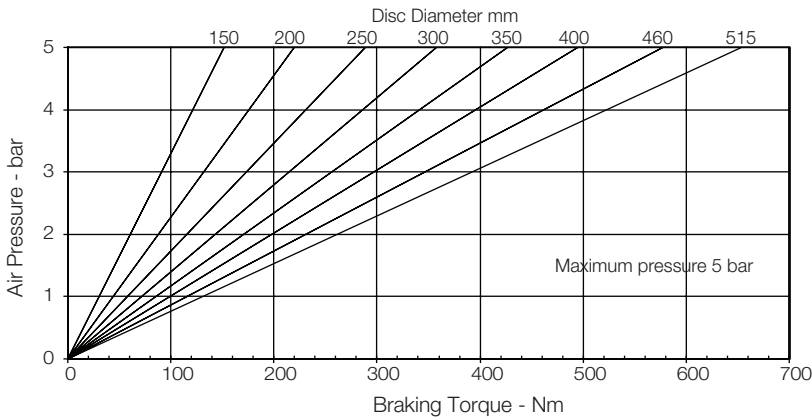
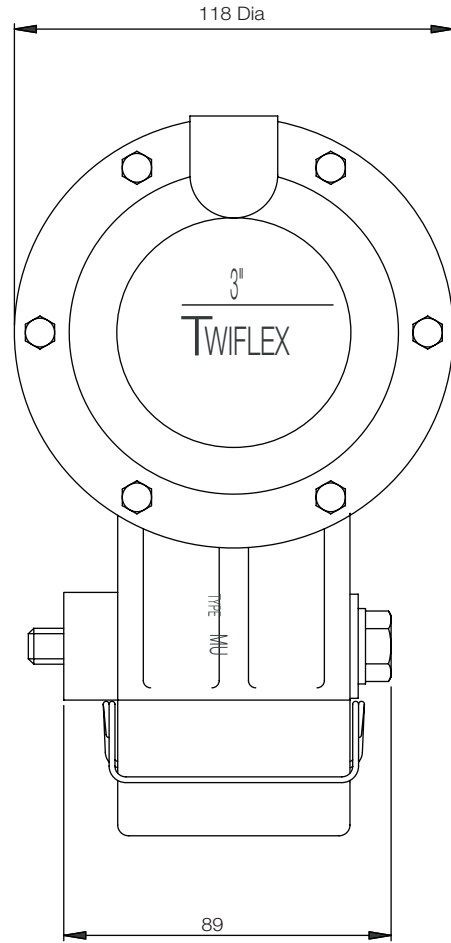
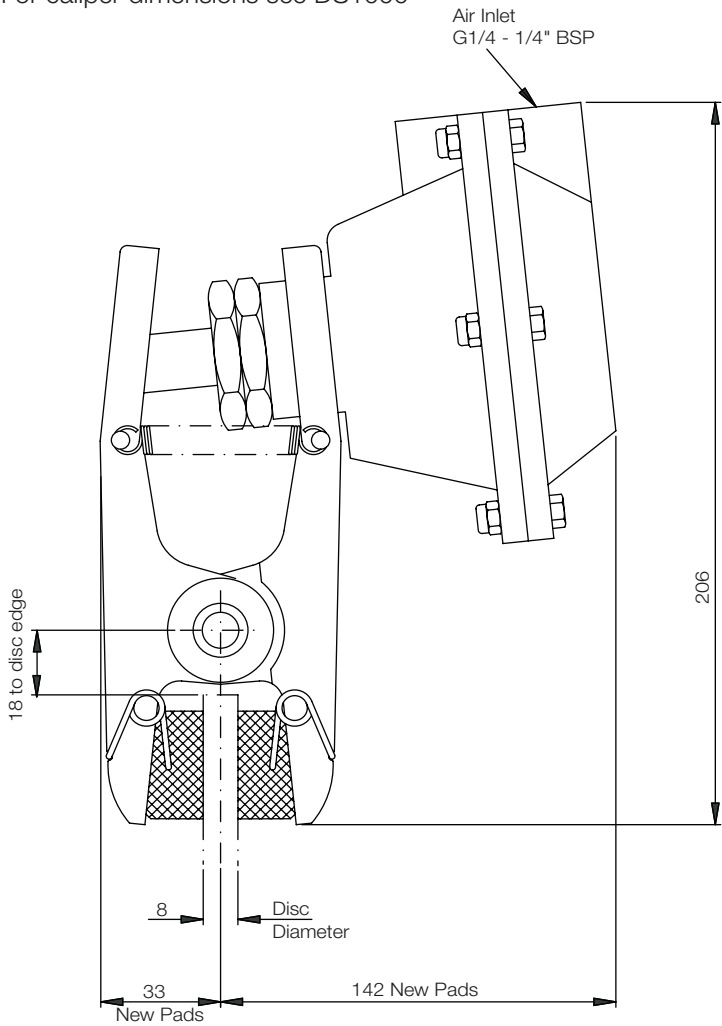

Weight (caliper and thruster) - 1.9kg
(thruster only) - 1.15kg
Volume displacement of thruster at
13mm stroke is 300ml.

Maximum Braking Force = 2.75kN @ 5

The ratings shown on the above graph are based on fully bedded and conditioned brake pads with nominal friction coefficient $\mu = 0.4$. For bedding-in and conditioning procedures see Publication M1060.

Braking Force is defined as the Tangential Force acting on the brake disc at the Effective Disc Radius.

Braking Torque (Nm) = Braking Force (N) x Effective Disc Radius (m) where Effective Disc Radius = Actual Disc Radius - 0.02.

Twiflex Disc Brakes must be used with Twiflex asbestos free brake pads. The use of any other brake pads will invalidate the warranty. Twiflex Limited reserves the right to modify or change the design without prior notice.

MU3 Disc Brake Caliper - Pneumatically applied Spring released

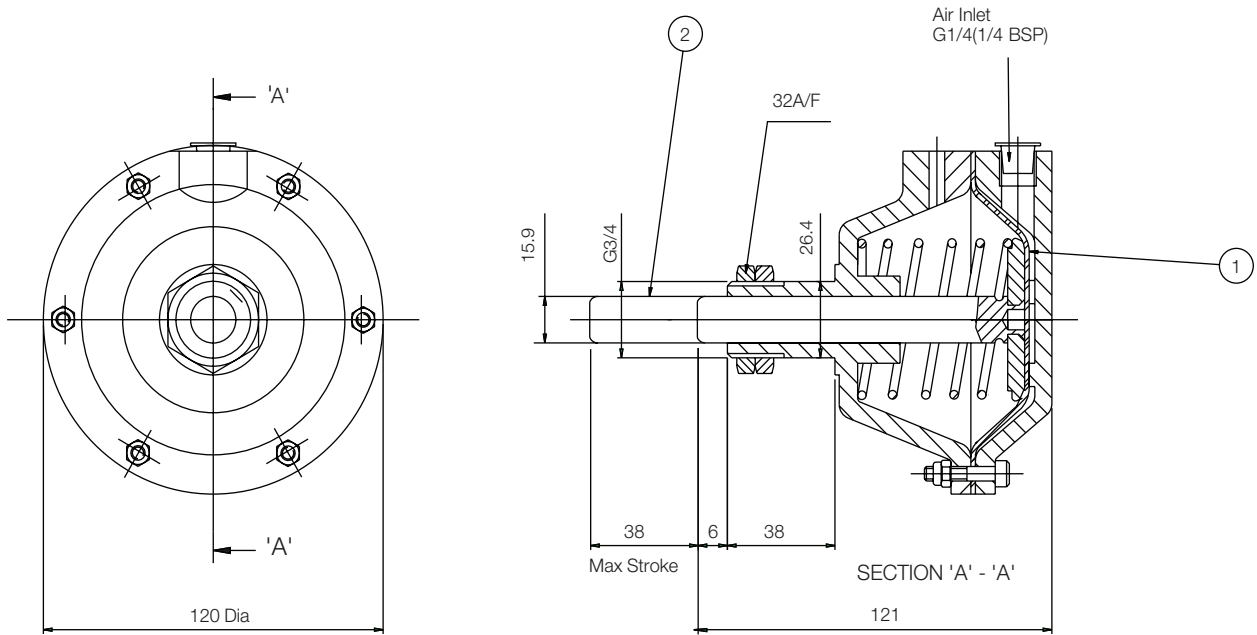

Thruster Part Number 7200923

AVAILABLE SPARES		
Item	Component	Part No.
1	Diaphragm Kit	7902797
2	Piston Rod Assembly	7200919

This range of pneumatically operated brakes uses dry and filtered compressed air at pressures up to 7 bar. Pneumatic brakes require a control valve which may be operated either manually, or by pneumatic or electrical signal. Should it become necessary to replace a diaphragm, ensure air supply is disconnected, remove the M5 fixing screws and the rear cap of the thruster. Remove the worn diaphragm; clean-up the contacting surfaces and re-assemble with the new diaphragm and fixing screws in position.

1. Offer thruster to caliper making sure that both lock nuts are removed before placing push rod through caliper arm
2. Fit Packing washer and spacer (see fig 1 and 2 below)
3. Fit lock nuts over the push rod
4. Tighten one lock nut to 50-60 Nm then tighten the second nut against the first

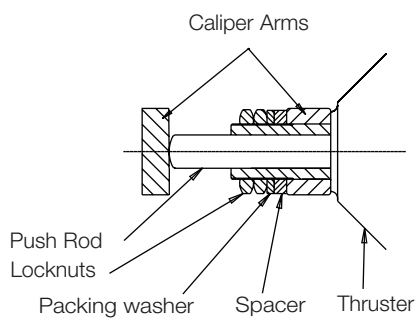

Fig 1. Assembly for 8mm disc

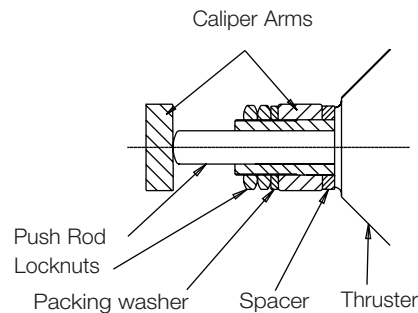

Fig 2. Assembly for 12.7mm disc